

TOWN OF ARUNDEL

257 Limerick Road
Arundel, ME 04046
www.arundelmaine.org

CODES ENFORCEMENT OFFICE

Phone (207)985-4201 ext. 107
ceo@arundelmaine.org

Radon System Requirements

Radon removal systems are now required in new low rise residential buildings, per the Maine Uniform Building and Energy Code, which is in effect Statewide. (Towns under 4000 population don't have to enforce it, but the Code is in effect in all Maine municipalities.) The radon standard, that contains the installation requirements, is ASTM E 1465- 08. It's available on our website. It's a long, complicated document, that is written more like a textbook than a code, and it's not easy to tell from it what is required for the typical system that is used in most buildings. This handout is a distilled version of the standard, with the requirements for a typical system, and the pertinent sections of the standards [referenced in brackets] that give the material specifications and installation methods, primarily for the people designing buildings and installing the piping.

The typical radon removal system consists of:

1. A 20' long perforated 4" PVC pipe, or a loop if it, underneath the basement slab, in crushed stone, (the "soil gas collector"), with a tee in it that comes up through the floor. [6.4.2] The interior foundation drainage piping can double as the radon collection pipe, if it's run into a sump with a check valve, before leaving the building, as detailed below. [6.4.4.32]
2. A 6 mil polyethylene "soil gas retarder" with 12" overlapped seams over the crushed stone.
3. A 4" or 3" [6.5.3.1 - buildings with a footprint over 1500 square feet have to be 4"] non perforated schedule 40 PVC pipe, running up through the building, within the thermal envelope, and through the roof, with space near the roof, or above it, for a fan to be added if needed (The system is to be under negative pressure where it passes through the house. The fan cannot be in the basement.). Near the roof, there has to be space for a 2' diameter x 3' tall cylinder of clear space, in case a fan is needed, with an electrical feed from the panel provided to that space, whether the system has a fan or not.

The foundation drainage has to be such that the radon system can't suck clean air from outdoors through the foundation drainage system. If the building has interior foundation drainage, that has to discharge into a sump in the floor of the basement or crawl space with a check valve in the discharge line, and a bolted, gasketed lid [6.2.4.2, and Figures 9 & 10J]. The check valve will be normally shut, keeping outdoor air out, unless water pushes it open. If the exterior drainage is being piped into an indoor sump to be pumped away (for flat sites where you can't daylight the end of the drain pipe), the same setup is required.

The vent stack must be run inside the thermal envelope of the building, and must terminate above the roof, at least 10' above ground, at least 2' above, or 10' away (horizontally) from any opening into conditioned or occupiable space in the building, or the top of a chimney. The same separation requirements apply to adjacent buildings.

The system can be designed with or without a fan [minimum 75 cfm]. A radon test has to be conducted [6.9.5], and a reading below 4 picocuries is required for occupancy. If a passive system (no fan) yields a reading higher than that, then the fan is added and the test redone.

Table 1, below, gives a list of the installation steps. Figure X 2.1, at the end, is a drawing showing the system components. There is more information in the entire standard about requirements not covered in this handout. This handout contains the basics for designing and installing the system.

There are two versions of this handout. The full, 21 page one, for designers and installers, and a 3 page version, primarily for earthwork contractors, who install the radon and drainage piping under the floor. If you can't find referenced sections, it's because you have the 3 page version. The full one is on our website, along with the entire standard.

If you have questions or need more information, let us know.

OE1465-08

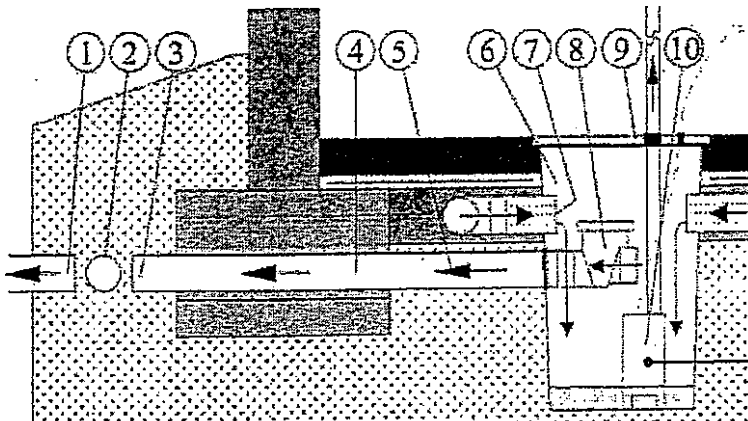

FIG. 9 Interior Perimeter Drain with Sump Pump and Gravity Dewatering

The pump is optional.
This is the setup for gravity draining the Interior drain piping
If there is a radon system.

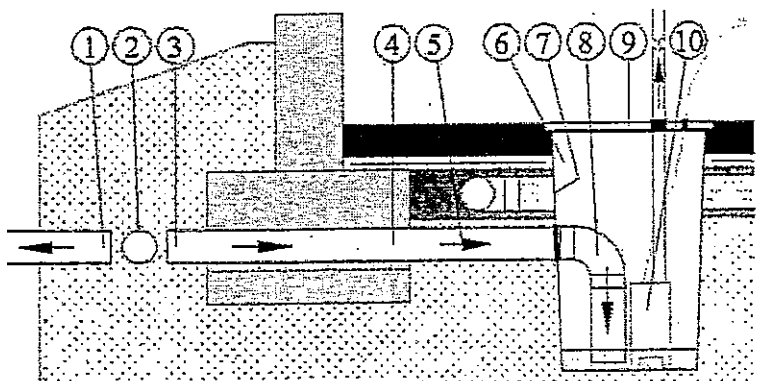

FIG. 10 Exterior Perimeter Drain with Sump Pump and Gravity Dewatering

TABLE 9 Permitted Perimeter Drain Configurations

Configurallon Number: Perimeter Drain Type:	1 Interior	2 Interior	3 Interior	4a w/sump Exterior	4b w/o sump Exterior	5 Exlerlor	6 Exlerlor	7 Interior and Exterior	8a sump 1 Interior and Exterior	8b sump 2 Interior and Exterior	9a sump 1 Interior and Exterior	9b sump 2 Interior and Exterior
Dewatering Method:	gravity	pump	gravity and pump		gravity	pump	gravily and pump	gravily	pump for Inlerlor	pump for exterior	gravity for Inl. and ext.; pump for Interior	pump for exterior
Reference Figure:	Ffg. 9	Fig. 9	Fig. 9	Fig. 10	Fig. 10 A	Fig. 10	Fig. 10	Fig. 9	Fig. 9	Ag. 10	Fig. 9	Fig. 10
Item 1 Type of run-off pipe (Item 1) -run-cliff pipe runs by gravity to dry well, daylight, stonn sewer, and so forth. A) Dedicated interior drain, B) Dedicated exterior drain, C) Merged exterior and Interior drain, D) None	A	none	A	A	B	none	B	(A and 8) or (C)	none	none	(A and B) or (C)	none
Item 2 Exterior perimeter drain (Item 2) is connected to: A) Item 1 gravity run-off (see Item 1 for type), B) Item 3 uoutside end of thru-footing" pipe, C) Nothing, D) n/a (ext. per. drain is not present)	n/a	n/a	n/a	A and B	A	B	A and B	A and B	nothing	B	A and B	B
Item 3 outside end of thru-footing pipe (see Item 3) is conneded to: A) Item 1 run-off (see Item 1 for type), B) Item 2 exterior perimeter drain pipe, C) n/a elhru-foolung drain pipe is nol present)	A	n/a	A	B	n/a	B	B	A	n/a	B	A	B
Item 4 thru-footing pipe A) Required or B) Prohibited	required	prohblled	required	required	prohibited	required	required	required	prohibited	required	required	required
Item 5 Gravity Drain Pipe Flow Direction: A) Out of building (out), B) Inlo building (in), C) n/a ("thru-footing" drain pipe is not preselt)	out	n/a	out	in	n/a	in	in	out	n/a	In	out	In
Item 6 Sump tub: A) Required or B) None	required	required	required	required	none	required	required	required	required	required	required	required
Item 7 Interior perimeter Drain connection: soil-gas collector shall penetrate sides of sump tub. A) Required, B) Prohibited, or C) n/a	required	required	required	prohblled	n/a	prohibited	prohibited	required	n/a	prohibited	required	prohibited
Item 8 Inside end of thru-footing" drain pipe is connected to: A) Backwater valve (BV) -required, B) Water Trap (WT)-Recommended, C) n/a ("thru-footing dral pipe is not present)	BV	na	BV	WT	n/a	WT	WT	BV	n/a	WT	BV	WT
Item 9 Sump tub cover style: A) Blank, B) Drilled (for sump pump connections) or, C) n/a (no sump tub is present)	blank	drilled	drilled	blank	n/a	drilled	drilled	blank	drilled	drilled	drilled	drilled
Item 10 Submersible sump pump A) Required or, B) None	none	required	required	none	none	required	required	none	required	required	required	required

A Configuration 4b is a tee fitting in the exterior perimeter drain that directs water by gravity to a run-off drain pipe.

8 Configurations 7 and 9a permit joining of interior and exterior perimeter drains to use a common run-off drain, but only outside the building's footprint. Configurations 7 and 9a also permit the interior and exterior drains to have separate dedicated run-off pipes.